

# **Electromagnetic Flowmeter Converter User Manual**

(511 Series)

# CONTENTS

<b>1. THE PRODUCT FUNCTION INTRODUCTION.....</b>	<b>1</b>
1.1    BASIC FUNCTION .....	1
1.2    ESPECIAL FUNCTION .....	1
1.3    NORMAL OPERATING CONDITIONS .....	2
1.4    TYPE OF CONNECTING WITH SENSORS .....	2
1.5    PLOT OF INSTALLING MEASURE .....	2
<b>2. BASIC CIRCUIT OF CONVERTER.....</b>	<b>4</b>
<b>3. INDEX OF TECHNICAL PERFORMANCE.....</b>	<b>4</b>
3.1    STANDARD OF IMPLEMENT .....	4
3.2    BASIC PARAMETERS AND PERFORMANCE INDEX.....	4
<b>4. OPERATION CONVERTER.....</b>	<b>7</b>
4.1    KEYS AND DISPLAY .....	7
4.2    SECTION PICTURE OF CONVERSION.....	8
4.3    CONNECTIONS OF CONVERSION .....	8
4.4    CHARACTERISTIC AND CONNECTION OF CABLE .....	11
4.5    DIGITAL OUTPUT AND CALCULATE.....	15
4.6    SIMULATION SIGNAL OUTPUT AND CALCULATE.....	18
<b>5. SETTING PARAMETERS.....</b>	<b>21</b>
5.1    511_4 KEY PARAMETERS AND SETTING .....	21
5.2    DETAILS PARAMETERS .....	26
<b>6. INFRARED TELECONTROL FUNCTION KEYS .....</b>	<b>33</b>
<b>7. ALARM INFORMATION.....</b>	<b>33</b>
<b>8. TROUBLESHOOTING.....</b>	<b>34</b>
8.1    NO DISPLAY:.....	34
8.2    EXCITING ALARM .....	34
8.3    EMPTY PIPE ALARM .....	34
8.4    MEASURE FLOW DISALLOW .....	35
<b>9. 511 ENCASMENT AND RESERVE.....</b>	<b>35</b>
9.1    511 ENCASMENT .....	35
9.2    SHIPPING AND STORAGE .....	35
<b>APPENDIX ONE: SELECTION OF EXCITING FREQUENCY (RE.) .....</b>	<b>36</b>
<b>APPENDIX TWO:ANALOG LOOP COMMUNICATION FUNCTION EXPLANATION</b>	<b>38</b>
<b>APPENDIXFOUR:511SERIESWITHNONLINEARAMENDMENTFUNCTIONADDITI</b>	
<b>ONAL INSTRUCTION .....</b>	<b>39</b>
<b>APPENDIXFIVE:THE FUNCTION OF PROTECTING THE CHARACTERISTIC</b>	
<b>FLOW FACTOR .....</b>	<b>40</b>

**APPENDIX SIX LIGHTNING PROTECTION NOTES..... 41**

## Electrometric Flowmeter Converter Instruction Manual

### 1. The product function introduction

#### 1.1 Basic function

- Low-frequency square-wave exciting, exciting frequency: 1/16power frequency、1/20power frequency、1/25 power frequency;
- High-frequency square-wave exciting, exciting frequency: 1/2 power frequency (for grouting liquid measure) (choose) ;
- Exciting current can be selected for 125mA、187.5mA、250 mA、500 mA;
- No need to add empty pipeline measurement, and can measure continuously, alarm by fixed value;
- Current speed range: 0.1 --- 15m/s, current speed resolution: 0.5mm/s;
- AC high-frequency switching power, range of voltage: 85VAC --- 250VAC;
- DC 24V switching power, range of voltage: 20VDC --- 36VDC;
- Network function: MODBUS、GPRS、PROFIBUS 、Analog Loop Communication interface (choose) ;
- Chinese or English displaying mode, (other languages can be set);
- Three integrator gross inside, respective register: Forward gross, reverse gross and minus value gross.

#### 1.2 Especial function

- Recording time when power turn-off, to record power broken time of instrument system automatically and recruit to count the missing flux;
- Recording function of hour gross, to record the flux gross by hour, fit for timed measure;

- Infrared handing telecontrol keyboard, all the functions of far-untouched controlling converter.

### 1.3 Normal operating conditions

Ambient Temperature Ranges: fission  $-10\sim+60^{\circ}\text{C}$ ;

Relative Humidity:  $5\sim90\%$ ;

Power Supply:  $85\sim250\text{V}$ ,  $45\sim63\text{Hz}$  ( single-phase AC).

Dissipation Power:  $<20\text{W}$  ( After connecting sensor ) .

### 1.4 Type of connecting with sensors

- The integrated circinal shells: circinal shells, shells connect with the flange directly, explosion-proof;

### 1.5 Plot of installing measure

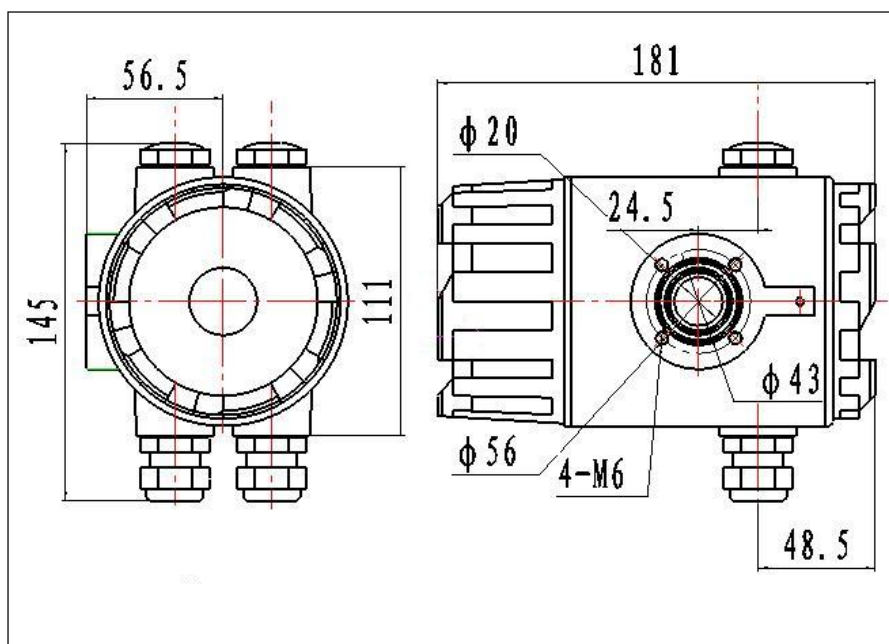

Fig.1.1 511 series

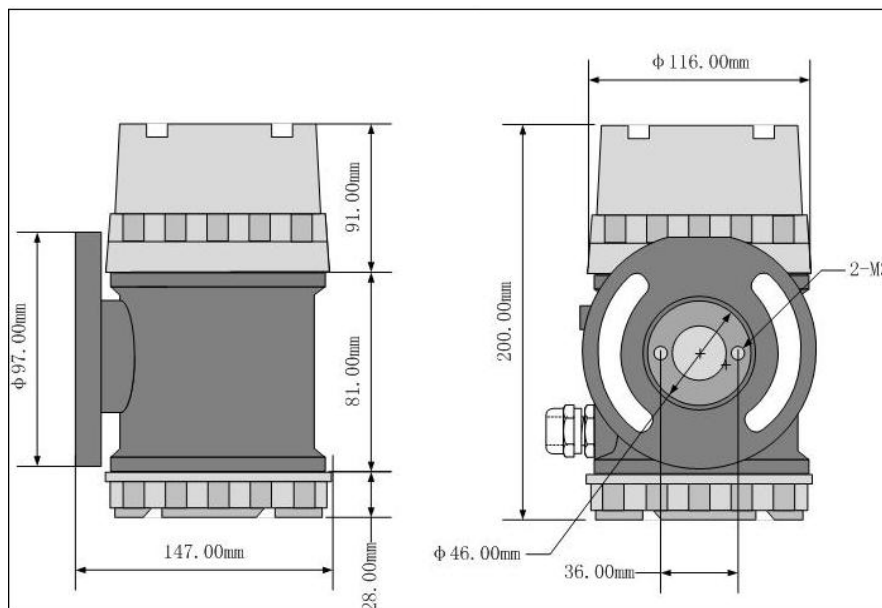

Fig.1.2 511B series

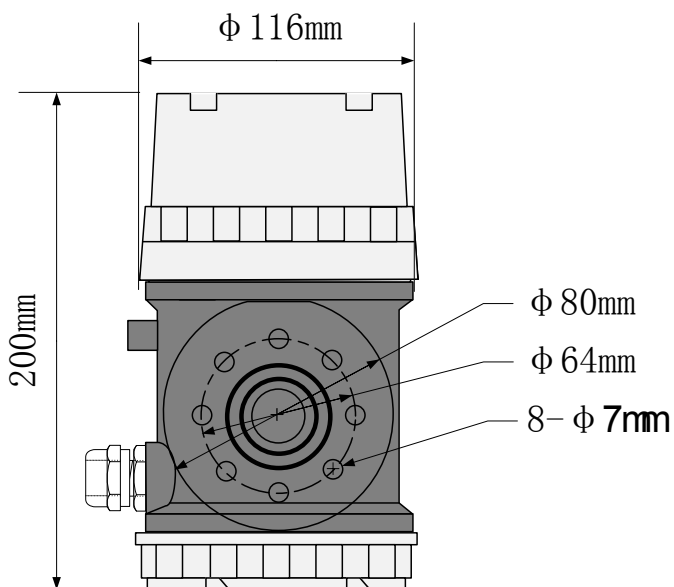

Fig.1.3 511B series 511C Shell

## 2. Basic circuit of converter

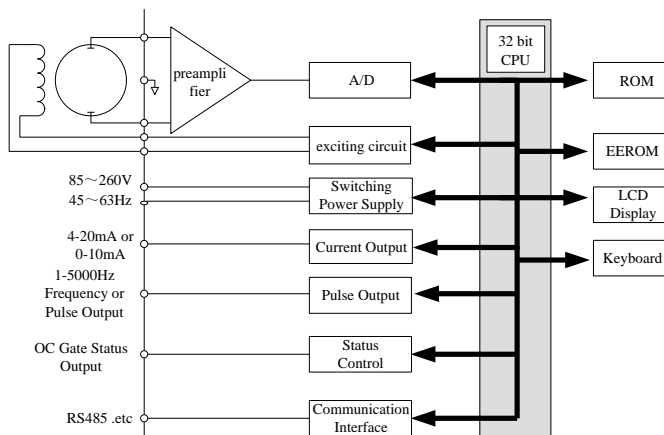

Fig.2. 1 Structure Of Converter's Circuit

The converter can supply exciting current to the coil in the sensor of electronic flowmeters, the head amplifier amplifies the electromotive force from the sensor and converts it into standard signals of current or frequency so that the signals can be used for displaying, controlling and processing. See structure of converter circuit shown in Fig.2.1.

## 3. Index of technical performance

### 3.1 Standard of implement

The design, production and instrument of **511** Electromagnetic Flowmeter Converter implement 《JJG-1033-2007Electromagnetic Flowmeters》.

### 3.2 Basic parameters and performance index

#### 3.2.1 Pipe's inside diameter of relative sensor (mm):

3、 6、 10、 15、 20、 25、 32、 40、 50、 65、 80、 100、 125、 150、 200、 250、 300、 350、 400、 450、 500、 600、 700、 800、 900、 1000、 1200、 1400、 1600、 1800、 2000、 2200、 2400、 2600、 2800、 3000;

#### 3.2.2 Request of relative sensor

Sensitivity of sensor signal: under 1m/s, output 150 $\mu$ V ~200 $\mu$ V;

For B electromagnetic flowmeter signal converters, there are four currents of 62.5 mA in exciting loop, which make up of 250mA, and every 62.5mA is controlled by one 20 $\Omega$  exact resistance. So user can choose different exciting current by changing the number of exact resistance.

The current will be 250mA when the signal converters leave factory, as such, if there are three exact resistance, the current will be 187.5 mA; if two, 125mA;

Resistance of sensor exciting coil:

500mA exciting current: 20 ~ 30 $\Omega$ ;

250mA exciting current: 50 ~ 60 $\Omega$ ;

187mA exciting current: 60 ~ 80 $\Omega$ ;

125mA exciting current: 100 ~ 120 $\Omega$ ;

### 3.2.3 Measure precision for assembly

Table 3.1  $V_S$ : Setting measurement range (m/s)

Diameter(mm)	Range(m/s)	Accuracy
3 ~ 20	$\leq 0.3$	$\pm 0.25\%FS$
	0.3~1	$\pm 1.0R$
	1~15	$\pm 0.5\%R$
25 ~ 600	0.1~0.3	$\pm 0.25\%FS$
	0.3~1	$\pm 0.5\%R$
	1~15	$\pm 0.3\%R$
700~3000	$\leq 0.3$	$\pm 0.25\%FS$
	0.3~1	$\pm 1.0\%R$
	1~15	$\pm 0.5\%R$
%FS: for relative ranges;		
%R: for relative value of measurement		



### 3.2.4 Simulated current output

Load resistor: 0~750Ω (4~20mA).

Basic Errors: 0.1%±10μA.

### 3.2.5 Digital frequency output

Frequency output range: 1~5000Hz;

Output electric isolate: Photoelectric isolate. Isolate voltage: > 1000VDC;

Frequency output drive: output by field-effect transistors, the highest subjected voltage is 36VDC, maximum of output current is 250 mA.

### 3.2.6 Digital pulse output

Pulse output range: 0 ~100 pulse/s. (When higher than upper limit, pulse will lose);

Pulse output value: 0.001~1.000 m<sup>3</sup>/cp、

0.001~1.000 Ltr / cp、

0.001~1.000 ukg/ cp、

0.001~1.000 usg/ cp、

Pulse output width: setting by user.

Pulse output isolate: photo electricity isolate. Isolate voltage: > 1000VDC;

Pulse output drive: output by field-effect transistors, the highest subjected voltage is 36VDC, maximum of output current is 250 mA.

### 3.2.7 Alarm output

Alarm output junction: ALMH--- upper limit; ALML--- lower limit;

Output isolate: photo electricity isolate. Isolate voltage: > 1000VDC;

Alarm output drive: output by Darlington pipe, the highest subjected voltage is 36VDC, maximum of output current is 250 mA.

### 3.2.8 Digital communication port and protocol

MODBUS interface: format of RTU , electric isolate 1000V;

Analog Loop Communication interface: designed by standard of Analog Loop Communication , if you choose our hand held unit , you can display the measure value on line,and setting the parameters.

### 3.2.9 Electric isolate

Insulated voltage between simulated input and simulated output should be higher than 500V;

Insulated voltage between simulated input and alarm power supply should be higher than 500V;

Insulated voltage between simulated input and AC power supply should be higher than 500V;

Insulated voltage between simulated output and AC power supply should be higher than 500V;

Insulated voltage between simulated output and earth should be higher than 500V;

Insulated voltage between pulse output and AC power supply should be higher than 500V;

Insulated voltage between pulse output and earth should be higher than 500V;

Insulated voltage between alarm output and AC power supply should be higher than 500V;

Insulated voltage between alarm output and earth should be higher than 500V;

## 4. Operation converter

### 4.1 Keys and display

\_4Keys and display

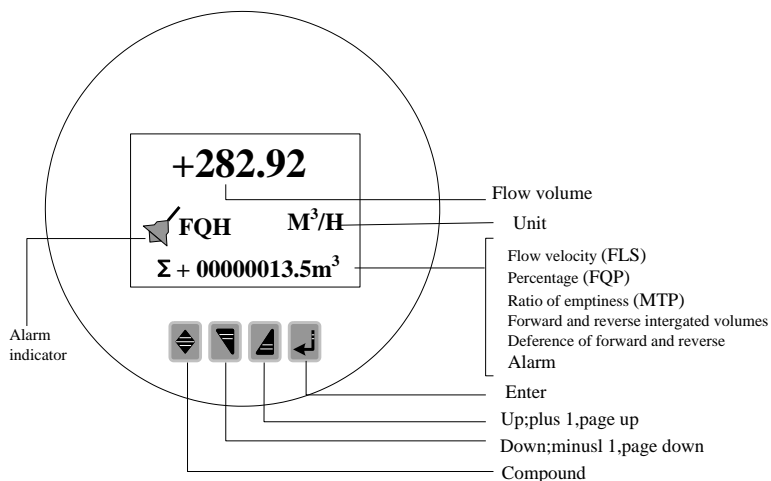

Note: When measuring, pushing down “Compound Key + Enter” will appear password of changing state, base on distinction of secrecy, and change the password as we provide. Then pushing “Compound Key + Enter” again, and you can inter the state of setting parameter. If want to return to the running state, push “Enter” for several seconds.

## 4.2 Section picture of conversion



511-4 Key



511B-4 Key

## 4.3 Connections of conversion

### 4.3.1 511 Connectors and labels

#### 4.3.1.1 Labels of connectors in squared model

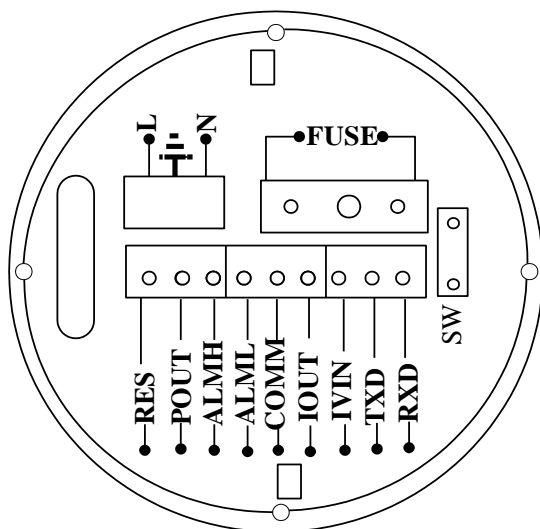

#### 4.3.1.2 Labels of connectors in squared model

IOUT:	Current Output of Flux (Two Routes Out)
IVIN	Two Routes 24V Power Supply
POUT:	Frequency(Pulse) Output for Bi-directional Flow
COMM:	Frequency, Pulse and Current Common (GND)
ALML:	Alarm Output for Low Limit
ALMH:	Alarm Output for Upper Limit
RES:	Connect Pull Resistance
TXD	Communication Signal Input(RS485-A)
RXD:	Communication Signal Input(RS485-B)
L:	220V Power Supply
N:	220V Power Supply

#### 4.3.2 511B Connectors and labels

##### 4.3.2.1 Labels of connectors in squared model

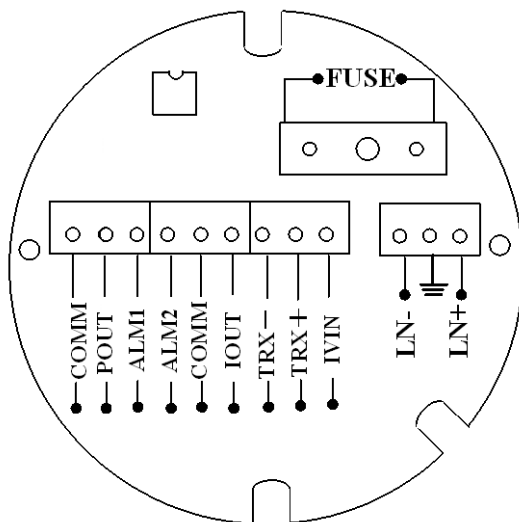

Fig.4.3 Connectors and labels

4.3.2.2 Labels of connectors in squared model

POUT:	Frequency(Pulse) Output for Bi-directional Flow
ALM1:	Alarm Output for Upper Limit
ALM2:	Alarm Output for Low Limit
COMM:	Frequency, Pulse and Current Common (GND)
COMM:	Frequency, Pulse and Current Common (GND)
IOUT:	Current Output of Flux (Two Routes Out)
IVIN	Two Routes 24V Power Supply
TRX+	+Communication Signal Input(RS485-A)
TRX-:	-Communication Signal Input(RS485-B)
LN+:	220V Power Supply
LN-:	220V Power Supply

## 4.4 Characteristic and connection of cable

### 4.4.1 Labels and connection of signal lines

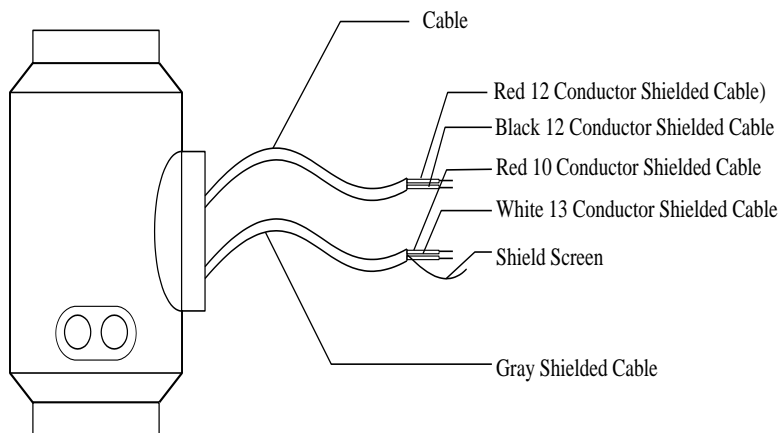

Fig.4.4.1 Labels and connection of signal lines in circinal model

Signal lines labels in circinal model:

twisted-pair cable (for exciting current): 12 Conductors (Red)

12 Conductors (Black)

Gray shielded twisted-pair cable: 10 Conductors (Red) connected to “Signals 1”

13 Conductors (white) connected to “Signals 2”

Shielded Conductor connected to “Signal Ground”

### 4.4.2 Flux signal line

When separated models of converters are assembled with sensors for measuring flow of fluid which conductivity is larger than  $50\mu\text{S}/\text{cm}$ , RVVPB2\*0.12\*280 mm<sup>2</sup> model cable ( metal shielded signal cable covered with PVC) can be used as communication cable for flow signals. The length of signal cable should be less than 100 m. Signal cables have to be connected to sensors that were assembled by producers. Connections of signal cables are shown in Fig.4.4.1.

The converter can output equivalent level of shielded exciting signal voltage so that interference to flow measurement signals can be reduced by means of lowering the distributed capacitance of communication cable. When measured conductivity is less than  $50\mu\text{S}/\text{cm}$  or signals are transferred in remote distances, double-conductor and double-shielded signal cable at equivalent level of voltage can be used. For example, special STT3200 cable or BTS model signal cable (triple-shielded) can be used for signal communication.

#### 4.4.3 Exciting current cable

Two conductor and insulating rubber-covered cables can be used as exciting current cables. Suggested model is  $\text{RVVP}2*0.12*250\text{mm}^2$ . Length of exciting current cable should be equal to that of signal cable. When the model STT3200 cables are used for exciting current and signals, two cables can be put together as one cable.

#### 4.4.4 Output and power line

All cables for signals transferring and power supply have to be prepared by users. However, it should be careful to choose the cables that meet the upper limit load of consuming current.

Pulse current output, alarm current output and external power supply can be seen in Fig.4.4.2(a). When inductive load is connected to converter, diode should be used as in Fig.4.4.2(b).

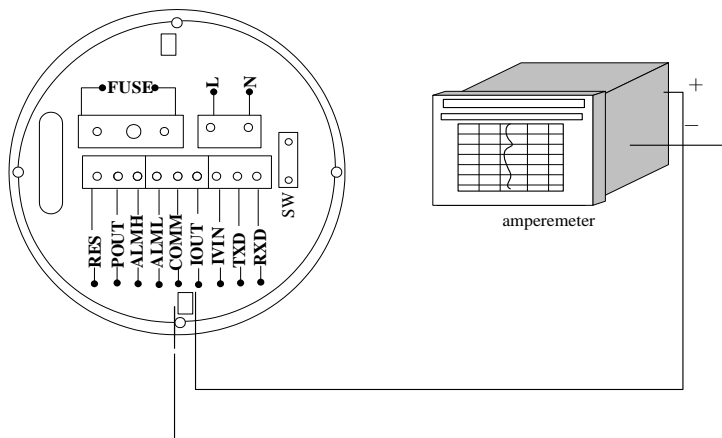

Fig 4.4.2(a) Output and power supply cables

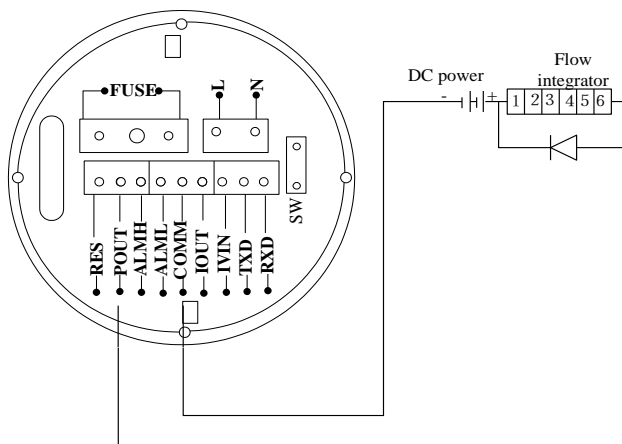

Fig 4.4.2(b) Connection of Electro-Mag 511Bnet Counter

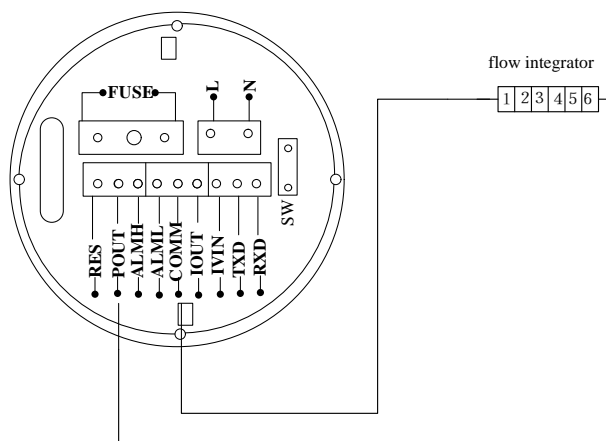



Figure 4.4.2 (c) Connection of Electronic Counter

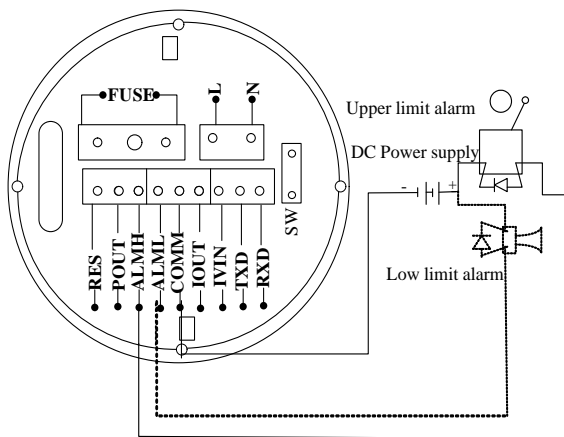

Fig 4.4.2(d) Connection of Alarm Output

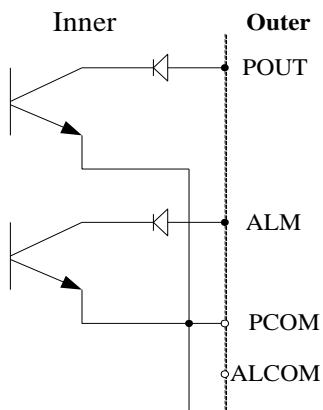

Fig.4.4.2(e) Connection of OC Gate

#### 4.4.5 The grounding requirements when installing convert

Contact area of copper Connector PE on Converter Cabinet for grounding should be larger than  $1.6\text{mm}^2$ . Contact resistance should be less than  $10\Omega$ .

First, purple copper tube should be cut into 1700 mm long (the copper tube can be lengthened according to the need ) to make the nail buried 1500 mm into the ground (Note : when burying nail, sprinkling a layer of broken charcoal at the top of nail, and then saline irrigation).

Then, 4mm<sup>2</sup> purple copper wire should be welded to the nail. At last, connecting ground wire to convert's flange, ground ring and pipeline's flange. It is shown in figure 4.4.5.

Note: Stainless steel must be used when fixing ground screws, spring washers and flat washers.

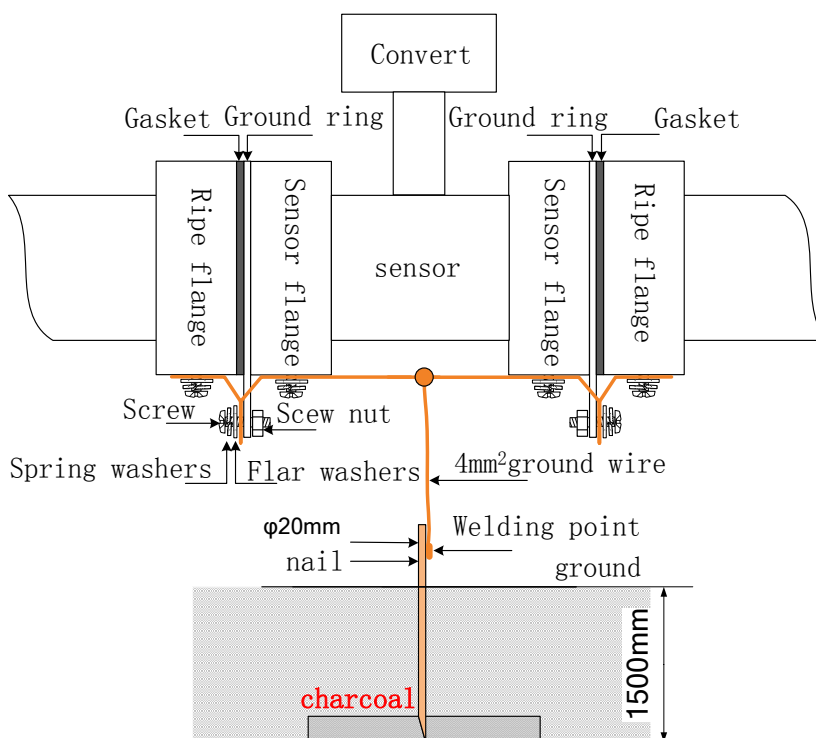

Fig.4.4.5 Grounding

## 4.5 Digital output and calculate

Digital output means frequency output and pulse output, and both of them use the same output point, so user can choose only one type of them but not both.

### 4.5.1 Frequency output

Frequency output range is 0~5000HZ, and corresponding the percent of flux.

$$F = \frac{\text{Measure value}}{\text{Full scale value}} \bullet \text{ frequency range}$$

The up limit of frequency output can be adjusted. It can be chosen from 0 ~ 5000HZ, and also can be chosen low frequency: such as 0 ~ 1000HZ or 0 ~ 5000HZ.

Frequency output mode general can be used in control application, because it responses the percent flux. Users can choose pulse output when the equipment is applied to count.

#### 4.5.1 Pulse output mode:

Pulse output mainly applies in count mode. A pulse output delegates a unit flux, such as 1L or,1m<sup>3</sup>etc. Pulse output unit divide into 0.001L--1L, 0.001m<sup>3</sup>--1 m<sup>3</sup>,0.001UKG--1UKG,0.001USG--1USG.When users choose the pulse unit, they should notice the match of the flux range of flowmeter and pulse unit. For volume flux, count formula as follows:

$$Q_L = 0.0007854 \times D^2 \times V \text{ (L/S)}$$

$$\text{Or } Q_M = 0.0007854 \times D^2 \times V \times 10^{-3} \text{ (M}^3\text{/S)}$$

Note: D-nozzle (mm)

V-velocity of flow (m/s)

The oversize flux and too small pulse unit will be made the pulse output over the up limit. Generally, pulse output should be controlled below 3000P/S. However, the too small flux and too large pulse unit will be made the instrument exports a pulse long time.

Otherwise, pulse output is different from frequency output. When pulse output cumulates a pulse unit, it exports a pulse. Therefore, pulse output is not equality. Generally, measure pulse output should choose to count instrument, but not frequent instrument.

#### 4.5.3 The connection of digital output

Digital output has tow connected points: digital output connected point, digital ground point, and symbol as follows:

POUT ----- digital output point;

PCOM ----- digital ground point;

POUT is collector plough output, user may refer to next circuit to connect.

#### 4.5.4 The connection of digital voltage output

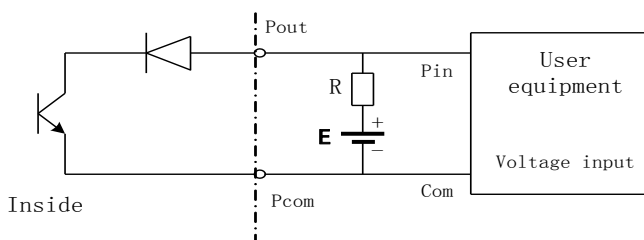

Fig.4.5(a) The connection of digital voltage output

#### 4.5.5 Digital output connect photoelectricity coupling (PLC etc.)

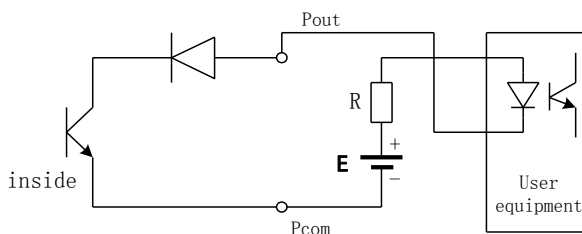

Fig.4.5(b) Digital output connect photoelectricity coupling

Commonly user's photoelectricity coupling current is about 10mA, so about  $E/R=10\text{mA}$ ,  $E=5\sim 24\text{V}$ .

#### 4.5.6 Digital output connect relay

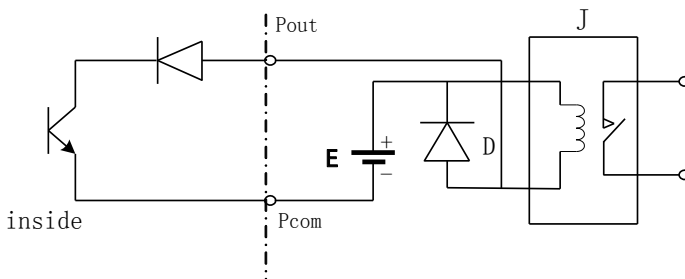

Fig.4.5 (c) Digital output connect relay

Commonly relay needs E as 12V or 24V. D is extend diode, now most middle relays has this diode inside. If not have, user can connect one outside.

Table of digital output parameter: POUT

Parameter	Test condition	Mini	Typical	Max	Unit
Volatge	IC=100 mA	3	24	36	V
Current	Vol≤1.4V	0	300	350	mA
Frequency	IC=100mA Vcc=24V	0	5000	7500	HZ
High voltage	IC=100mA	Vcc	Vcc	Vcc	V
Low voltage	IC=100mA	0.9	1.0	1.4	V

## 4.6 Simulation signal output and calculate

### 4.6.1 Simulation signal output

Simulation signal output inner is 24V under 4~20mA, it can drive 750Ω resistance.

The percent flux of simulation signal output:

$$I_0 = \frac{\text{Measure value}}{\text{Full scale value}} \bullet \text{the scale of current} + \text{the zero point of current}$$

The current zero is 4mA when 4~20mA.

It can be advanced simulation signal output distinguish. User can select the range of measure.

The manufacture's parameter have been adjusted, it can't need adjust. If have abnormity, it can consult 4.6.2.

### 4.6.2 Simulation Signal Output Adjust

(1)The Converter adjust preparative

When the converter is running 15 minutes, the inner of converter becomes stabilization. Preparative 0.1% amperemeter or 250Ω、 0.1% voltage instrument.

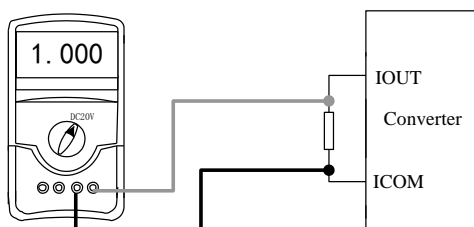

(2)Current zero correct

When the converter getting into parameter setting, selecting to “Analog Zero” and enter to it. The standard of signal fountain getting to “0”.Adjust parameter make amperemeter is 4mA(±0.004mA).

(3)The full scale current correct

To select “Anlg Range” to enter.Adjust the converter parameter make amperemeter is 20mA(±0.004mA)

Adjust the current zero and the full range, the current function of the converter reached exactness.The line degree of current output of conversion should be controlled within the scope of 0.1%

(4) Current line degree checking

You can place the standard signal source in 75%、50%、25%,and check the line degree of current output

4.6.3 511 electromagnetic flowmeter converter’s connection of current output:

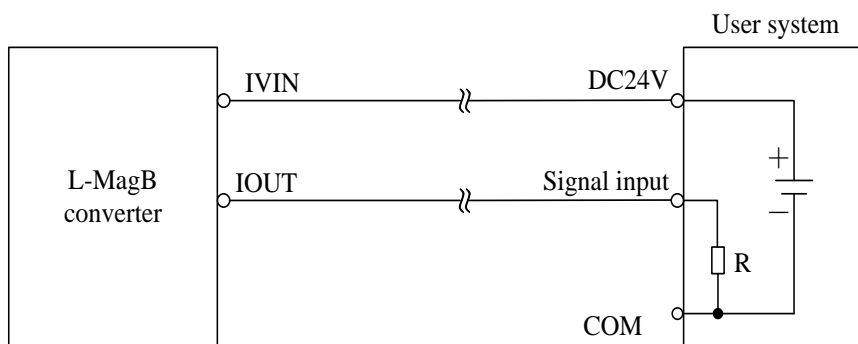

Fig.4.6 (a) L\_Mag 511 two connection

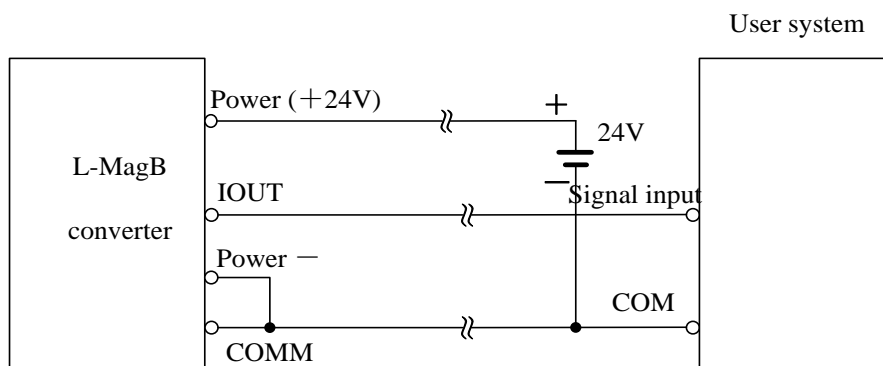

Fig.4.6 (b) L\_Mag 511 three connection( power supply and current output are not insulated)

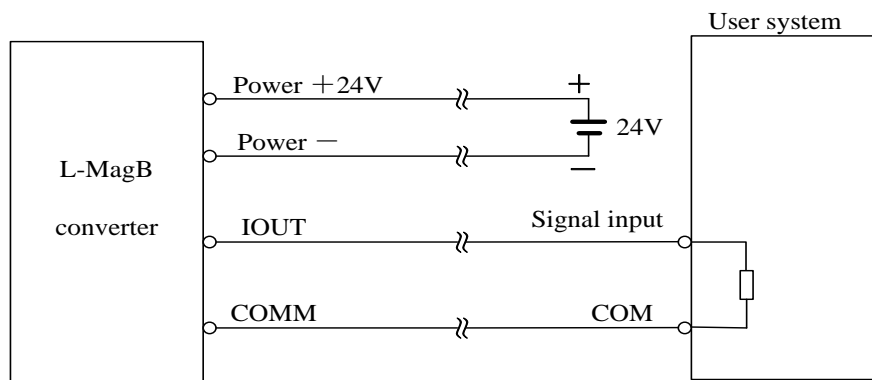

Fig.4.6 (c) L\_Mag 511 four connection( power supply and current output are insulated)

## 5. Setting parameters

After B electromagnetic flowmeter converter and sensor connect to the pipe (no matter demarcate or use), may do the next work first:

- Connect the pipe fore-and-aft the sensors tighten.
- Make sure the sensor connects the earth.
- Make sure the liquid stillness when regulating zero of the instrument.
- Make sure the oxidation velum of sensor makes steadily (electrode and liquid contact continuously about 48 hours).

### 5.1 511\_4 key parameters and setting

When electrify, the instrument comes into measure way automatically, and under this way it can do all the functions and display data. Under the parameter setting way, user can set the parameter by the four keys.

#### 5.1.1 Keys function

##### a) Keys' function in self- testing way

“Down” key: Selecting displayed data on lower line in turn;

“Up” key: Selecting displayed data on higher line in turn;

“Compound” key + “Enter” key: Come into parameter setting

“Enter” key: Press it to come into the picture of select function.

Under the measure, adjust of the LCD contract is used “Compound” key + “Up” key or “Compound” key + “Down” key for several seconds;

##### b) Function keys for parameters setting

“Down” key: Subtract 1 from the number at cursor area;

“Up” key: Plus 1 to the number at cursor area;

“Compound” key + “Down” key: Cursor turns left;



“Compound” key + “Up” key: Cursor turns right; “Enter” key: In/Out submenu;

“Enter” key: Press for two seconds under any state and will return to automate measure way.

Note: (1) When use “Compound” key, you should press “Compound” key and “Up” or “Down” both;

(2) It will return to the measure way automatically after 3 minutes when under the parameter setting way;

(3) Direct select of zero correction about the flow, you can move the cursor to the left + or - , and use “Down” or “Up” to switch;

### 5.1.2 Function keys for setting parameters

To set or correct working parameters, the converter should be running in parameters setting way instead of measuring status. In measuring status, push “Compound”+“Enter” keys getting to the select of parameter and transfer password (0000), and then correct the password with one of the new passwords that are provided by manufacturer. Finally, push the “Compound”+“Enter” keys to work in Parameters Setting Way.

There are 6 Passwords in design and among them 4 for deferent operators in secret and 2 are fixed passwords for system operation.

### 5.1.3. Functions select menu

Push “Compound”+“Enter” keys to the functions select menu, push “Up” or “Down” keys to select, there are two functions:

Code	Functions	Notes
1	Parameters Set	Select this function; It can enter the picture of parameter.
2	Clr Total Rec	Select this function, It can be gross reset operation.
3	Fact Modif Rec	Select this function, It can be check the factor

		's modif Record
--	--	-----------------

### 5.1.3.1 Parameters Set

Press “Compound”+“Enter” key, it displays “Parameters Set” function. Input password. Press “Compound”+“Enter” key, it getting to Parameters Setting status.

### 5.1.3.2 Clr Total Rec

To push “Compound”+“Enter” keys getting to the select of parameter, then push “Up” key to “Clr Total Rec”, input the passwords. When the passwords becomes “00000”, this function is done, the gross is 0 in the instrument.

### 5.1.3.3 Fact Modif Rec

To push “Compound”+“Enter” keys getting to the select of parameter, then push “Up” key to “Fact Modif Rec”(Detail consult the AppendixFive)

## 5.1.4 Setting Parameters in Menu

There are 54 parameters of 511, user can set every parameter. The List of Parameters is shown below:

Setting Parameters in Menu

Code	Parameter words	Setting Way	Grades	Range
1	Language	Select	2	English
2	Comm Address	Set count	2	0~99
3	Baud Rate	Select	2	600~14400
4	Snsr Size	Select	2	3~3000
5	Flow Unit	Select	2	L/h、 L/m、 L/s、 m <sup>3</sup> /h、 m <sup>3</sup> /m、 m <sup>3</sup> /s、 UKG、 USG
6	Flow Range	Set count	2	0~99999
7	Flow Rspns	Select	2	1~50
8	Flow Direct	Select	2	Plus/ Reverse
9	Flow Zero	Set count	2	0~±9999

《ELECTROMAGNETIC FLOW METER CONVERTER MANUAL》

10	Flow Cutoff	Set count	2	0~599.99%
11	Cutoff Ena	Select	2	Enable/Disable
12	Total Unit	Select	2	0.001m <sup>3</sup> ~1m <sup>3</sup> 、 0.001L~1L、 0.001ukg~1ukg、 0.001usg~1usg
13	SegmaN Ena	Select	2	Enable/Disable
14	Analog Type	Select	2	4~20mA
15	Pulse Type	Select	2	Freque / Pulse
16	Pulse Fact	Select	2	0.001m <sup>3</sup> ~1m <sup>3</sup> 、 0.001L~1L、 0.001ukg~1ukg、 0.001usg~1usg
17	Freque Max	Select	2	1~ 5999 HZ
18	Mtsnsr Ena	Select	2	Enable/Disable
19	Mtsnsr Trip	Set count	2	59999 %
20	Alm Hi Ena	Select	2	Enable/Disable
21	Alm Hi Val	Set count	2	000.0~ 599.99 %
22	Alm Lo Ena	Select	2	Enable/Disable
23	Alm Lo Val	Set count	2	000.0~599.99 %
24	Sys Alm Ena	Select	2	Enable/Disable
25	Clr Sum Key	Set count	3	0~99999
26	Snsr Code1	User set	4	Finished Y M
27	Snsr Code2	User set	4	Product number
28	Field Type	Select	4	Type1,2,3
29	Sensor Fact	Set count	4	0.0000~5.9999
30	Line CRC Ena	Select	2	Enable/Disable
31	Linary CRC1	User set	4	Set Velocity
32	Linary Fact 1	User set	4	0.0000~1.9999
33	Linary CRC2	User set	4	Set Velocity
34	Linary Fact 2	User set	4	0.0000~1.9999
35	Linary CRC3	User set	4	Set Velocity
36	Linary Fact 3	User set	4	0.0000~1.9999
37	Linary CRC4	User set	4	Set Velocity
38	Linary Fact4	User set	4	0.0000~1.9999

39	FwdTotal Lo	Correctable	5	00000~99999
40	FwdTotal Hi	Correctable	5	00000~9999
41	RevTotal Lo	Correctable	5	00000~99999
42	RevTotal Hi	Correctable	5	00000~9999
43	PlsntLmtEna	Select	3	Enable/Disable
44	PlsntLmtVal	Select	3	0.010~0.800m/s
45	Plsnt Delay	Select	3	400~2500ms
46	Pass Word 1	User correct	5	00000~99999
47	Pass Word 2	User correct	5	00000~99999
48	Pass Word 3	User correct	5	00000~99999
49	Pass Word 4	User correct	5	00000~99999
50	Analog Zero	Set count	5	0.0000~1.9999
51	Anlg Range	Set count	5	0.0000~3.9999
52	Meter Fact	Set count	5	0.0000~5.9999
53	MeterCode 1	Factory set	6	Finished Y/M
54	MeterCode 2	Factory set	6	Product Serial No

Parameters of converters can decide the running status, process and output ways as well as state of output. Correct option and setting of parameters can keep the converters running optimally and get higher accuracies of output both in display and in measurement.

There are 6 grades of passwords for setting parameters function. Grades 1 to grade 5 of passwords are for users and grade 6 of password is for manufacturer. Users can reset their passwords of grades 1~4 in grade 5.

Users can check converters parameters in any grade of password. However, if users want to change parameters of converters, different grade of parameters have to be used by the users.

Grade 1 of password (set by manufacturer as 00521): users can only read parameter.

Grade 2 of password (set by manufacturer as 03210): users can change 1~24 parameters.

Grade 3 of password (set by manufacturer as 06108): users can change 1~25parameters.

Grade 4 of password (set by manufacturer as 07206): users can change 1~38parameters.

Grade 5 of password (Fixed): users can change 1~52 parameters.

Password Grade 5 can be set by skilled users. Grade 4 is mainly used for resetting total volume in password. Grades 1~3 can be set by any one who can be chosen by users.

## 5.2 Details Parameters

### 5.2.1 Language

There are 2 languages for 511 converter operation. They can be set by users according to the users needs.

### 5.2.2 Comm Address

It means this instrument's address when communicates with many, and has 01~99, holding the 0.

### 5.2.3 Baud Rate

300,600, 1200, 2400, 4800, 9600, 19200, 38400baud rate.

### 5.2.4 Snsr Size

511 converters can be equipped with some deferent sensors that have deferent diameter of measuring pipes. The pipes in deferent diameters from 3mm to 3000mm can be chosen in relative table.

### 5.2.5 Flow unit

The flow unit can choose form the parameters (L/s、 L/m、 L/h、 m<sup>3</sup>/s、 m<sup>3</sup>/m、 m<sup>3</sup>/h、 UKG、 USG),and the user can choose the proper unit according to the technological requirement and using habit.

### 5.2.6 Flow Range

Flow range means upper limit value, and lower limit value is set "0" automatically. So,

it makes the range, and makes the relation of percent display, frequency output and current output with flow:

percent display = ( flow measure / measure range) \* 100 %;

frequency output = ( flow measure / measure range) \* frequency full;

current output = ( flow measure / measure range) \* current full + base point;

pulse output will not affect.

### 5.2.7 Flow Rspns

It means time of filter measure value. The long one can enhance the stability of flow display and output digital, and fits for gross add up of pulse flow; the short one means fast respond rate, and fits for production control. It is set by select.

### 5.2.8 Flow Direct

If users think the direct and design are differ, just change the direct parameter is OK, but not change exciting or signal.

### 5.2.9 Flow zero

Make sure the sensor is full of flow, and the flow is stillness. Flow zero is shown as velocity of flow, mm/s.

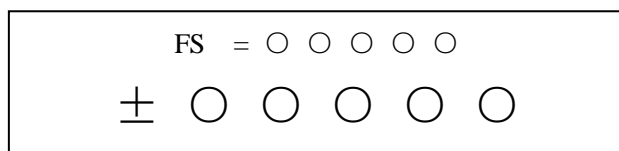

Converter's zero-flow correction displays like this:

Upper small words: FS means measure value of zero;

Lower large words: correction value of zero.

When FS is not "0", make FS = 0. Note: if change the value on next line and FS increases, please change the "+, -" to correct FS to zero.

Flow zero is the compound value of the sensor, and should be recorded in sensor list and band. The unit will be mm/s, and the sign will be opposite with correction value.

#### 5.2.10 Flow cutoff

Flow cutoff is set in percentage of Upper Limit Range of flow, and users can delete all Negligible Small Signals of flow volume, velocity and percentage out of displaying and outputting them. Sometimes user can delete output of current output signal and frequency (pulse) output signal only to have flow, velocity and percentage being displayed.

#### 5.2.11 Total Unit

Converter display is counter with 9 bits, and the max is 999999999.

Integrator units are L, m<sup>3</sup> (liter, stere,).

Flow integrator value: 0.001L、 0.010L、 0.100L、 1.000L  
0.001m<sup>3</sup>、 0.010m<sup>3</sup>、 0.100m<sup>3</sup>、 1.000m<sup>3</sup>;  
0.001ukg、 0.010ukg、 0.100ukg、 1.000ukg  
0.001usg、 0.010usg、 0.100usg、 1.000usg

#### 5.2.12 SegmaN Ena

When “SegmaN Ena” is “enable”, if the flow flows, the sensor will export pulse and current. When it is “disable”, the sensor will export pulse as “0” and current as “0”(4mA or 0mA) for the flow flows reversals.

#### 5.3.13 Analog Type

4~20mA practically.

#### 5.3.14 Pulse Type

Two kinds of Pulse Outputs are can be chosen: Frequency Output and Pulse Output. Frequency Output is continuous square waveform and Pulse output is a serial wave of square wave. Frequency output is mainly used for instant flow and total integrated flow in

short time measurement. Frequency output can be chosen in equivalent frequency unit and volume of integrated flow can be displayed. Frequency Output can be used in long time measurement for total integrated flow with volume units.

Frequency output and pulse output are usually from OC gates so that DC power supplies and load resistors have to be required (See Part 4.5).

#### 5.2.15 Pulse Fact

Equivalent pulse Unit is referred to one pulse for value of flow. The range of pulse equivalent can be chosen:

Pulse Equivalent	Flow	Pulse Equivalent	Flow
1	0.001L/cp	9	0.001ukg/cp
2	0.01L/cp	10	0.01ukg/cp
3	0.1L/cp	11	0.1ukg/cp
4	1.0L/cp	12	1.0ukg/cp
5	0.001m <sup>3</sup> /cp	13	0.001usg/cp
6	0.01m <sup>3</sup> /cp	14	0.01usg/cp
7	0.1m <sup>3</sup> /cp	15	0.1usg/cp
8	1.0m <sup>3</sup> /cp	16	1.0usg/cp

Under the same flow, the smaller pulse, the higher frequency output, and the smaller error will be. The highest pulse output is 100cp/s, and mechanism electromagnetic counter can get 25 frequency/s.

#### 5.2.16 Freque Max

Frequency output range is as the upper limit of flow measure, just the percent flow 100%. Frequency output upper limit can be selected between 1~5000Hz.

The state of empty pipe can be detected with the function of converter. In the case of Empty Pipe Alarm, if the pipe was empty, the signals of analog output and digital output



would be zero and displayed flow would be zero, too.

#### 5.2.17 Mtsnsr Ena

The state of empty pipe can be detected with the function of converter. In the case of Empty Pipe Alarm, if the pipe was empty, the signals of analog output and digital output would be zero and displayed flow would be zero, too.

#### 5.2.18 Mtsnsr Trip

When the pipe is full of liquid (whether flowing or not), the parameter of “Mtsnsr” could be modified more easily. The parameter displayed upper line is real MTP, and the parameter displayed bellow is the “Mtsnsr trip” that should be set. When setting “Mtsnsr trip”, you could be according to the real MTP, the value that should be set is usually three to five times of real MTP.

#### 5.2.19 Alm Hi Ena

Users can choose “Enable” or “Disable”.

#### 5.2.201 Alm Hi Val

The parameter of upper limit alarm is percentage of flow range and can be set in the way of setting one numerical value between 0%~199.9%. When the value of flow percentage is larger than the value of setting value, the converter outputs the alarm signal.

#### 5.2.21 Alm Lo Val

The same as upper limit alarm.

#### 5.2.22 Sys Alm Ena

Selecting Enable will have the function, and selecting Disable will cancel the function.

#### 5.2.23 Clr Sum Key

User use more than 3 byte code to enter ,Then set this password in Clr Total Rec.

#### 5.2.24 Snsr Code

It is referred to the produced date of sensor and the serial number of product that can keep the sensors coefficient right and accurate.

#### 5.2.25 Sensor Fact

“Sensor Coefficient” is printed on the Label of the sensor when it is made in factory. The “sensor coefficient” has to be set into Sensor Coefficient Parameter when it runs with converter.

#### 5.2.26 Field Type

511 affords three exciting frequency types: 1/16 frequency (type 1), 1/20frequency (type 2), 1/25 frequency (type 3). The small-bore one should use 1/16 frequency, and large-bore one should use 1/20 or 1/25 frequency. When using, please select type 1 first, if the zero of velocity is too high, select the type 2 or type 3.

Note: Demarcate on which exciting type, working on it only.

#### 5.2.27FwdTotal Lo、 hi

Positive total volume high byte and low byte can change forthcoming and reverse total value, and be used to maintenance and instead.

User use 5 byte code to enter, and can modify the positive accumulating volume ( $\Sigma+$ ). Usually, it is unsuitable to exceed the maximum the counter set (99999999) .

#### 5.2.28 RevTotal Lo、 hi

User use 5 byte code to enter, and can modify the negative accumulating volume ( $\Sigma-$ ). Usually, it is unsuitable to exceed the minimum the counter set (99999999) .

#### 5.2.29 PlsntLmtEn

For paper pulp, slurry and other serosity, the flow measure will have "cuspidal disturb", because the solid grain friction or concussion the measure electrode. 511

converters use variation restrain arithmetic to conquer the disturbing by designing three parameters to select disturb character.

Set it "enable", start variation restrain arithmetic; set it "disable", close variation restrain arithmetic.

#### 5.2.30 PlsntLmtVl

This coefficient can disturb the variation of cuspidal disturb, and calculate as percent of flow velocity, thus ten grades: 0.010m/s, 0.020m/s, 0.030m/s, 0.050m/s, 0.080m/s, 0.100m/s, 0.200m/s, 0.300m/s, 0.500m/s, 0.800m/s, and the smaller percent, the higher delicacy of cuspidal restrain.

Note: when using it, must test for select by the fact, and sometimes it is not the higher delicacy is good.

#### 5.2.31 PlsntDelay

This coefficient can select the width of time of restrain cuspidal disturb and the unit is ms. If the duration is shorter than flow change in some time, 511 will think it is cuspidal disturb, and if it is longer, 511 will think it is natural. It also needs to select parameter in fact.

#### 5.2.32 User's password 1~4

Users can use 5 grades of passwords to correct these passwords.

#### 5.2.33 Analog Zero

When the converters are made in the factory, output current has been calibrated to zero scale, that is, accurate 0mA or 4mA output.

#### 5.2.34 Anlg Range

When the converters is made in the factory, output current have been calibrated to full scale, that is, accurate 10mA or 20mA output.

### 5.2.35 Meter Fact

This fact is the special one of sensor-made-factory and the factory use this fact to unite 511 electromagnetic flowmeters converters to make sure all the instruments can interchange by 0.1%.

## 6. Infrared telecontrol function keys

The operation of the infrared-hand-remote control keyboard is the same with the operation of the instrument. When use it, please keep the infrared transmitter of the infrared-hand-remote control keyboard and the receiver of the instrument parallel, with the distance of about one meter.

Concrete operation referring to the figure:

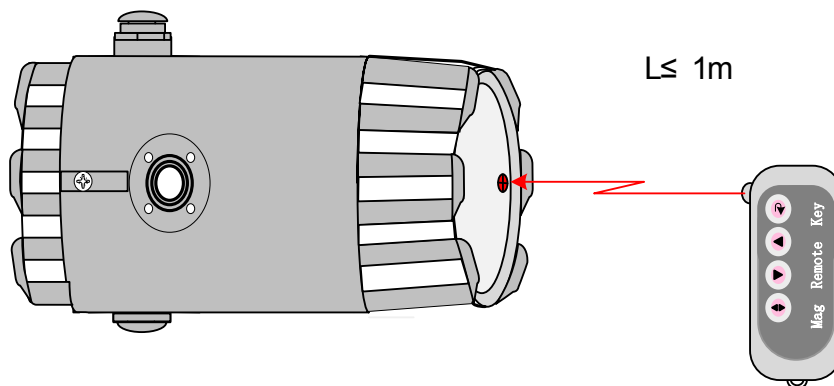

Fig6.1: The communication figure of the infrared-hand-remote control keyboard and the instrument

## 7. Alarm information

PCB of electromagnetic flowmeters converters uses SMT, so for user, it is unable to service, and cannot open the shell of converter.

**511-4 key** series Intelligent converters have self-diagnose function. Without trouble of power and hardware circuit, the normal trouble can be alarmed correctly. This information

displays  on the left of LCD. The trouble is like this:

FQH ---- Flow high limit alarm;      FQL ---- Flow low limit alarm;

FGP ---- Flow empty pipe alarm;      SYS ---- System exciting alarm.

UPPER ALARM ---- Flow high limit alarm;

LOWER ALARM ---- Flow empty pipe alarm;

LIQUID ALARM ---- Flow empty pipe alarm;

SYSTEM ALARM ---- System exciting alarm.

## 8. Troubleshooting

### 8.1 No display:

- a) Check the power supply connection;
- b) Check the power fuse to see for OK;
- c) Check the contrast of LCD and regulate it to working state;

### 8.2 Exciting alarm

- a) Check if the exciting cables EX1 and EX2 did not connected;
- b) Check if the total resistance of sensor's exciting coil resistances less than 150Ω;
- c) If a) and b) are OK, the converter is failed.

### 8.3 Empty pipe alarm

- \* If measured fluid full of testing pipe of sensor;
- \* When shorting circuit three connectors SIG 1, SIG 2, SIGGND of converter, and no "Empty Alarm" displayed then the converter works OK. In this case, it is possible that conductivity of measured fluid may be small or empty threshold of empty pipe and range of empty pipe are set wrongly.
- \* Check if the signal cable is OK;

- \* Check if the electro-poles are OK or not.

Let the flow is zero, then the displayed conductivity should be less than 100%.

Resistances of SIG1 to SIGGND and SIG2 to SIGGND are all less than 50k $\Omega$  (conductivity of water) during measurement operation. (It is better to test the resistances by means of multimeter with pointer to see the charging process well.)

- \* The DC voltage should be less than 1V between DS1 and DS2 testing the voltage by means of multimeter. If DC voltage is larger than 1V, the electro poles of sensor were polluted that have to be cleaned.

## 8.4 Measure flow disallow

- \* If measured fluid full of testing pipe of sensor;
- \* Check if the signal cable is OK;
- \* Check the sensor modulus and sensor zero whether set as the sensor escutcheon or

leave factory checkout.

## 9. 511 encasement and reserve

### 9.1 511 encasement

511 electromagnetic flowmeter converter is packed as vacuum, and can insulate wet.

The bag is 511's appropriate one, if the bag is open, it will not product of original factory.

Installation Manual, Certificate of Product and Packing List are all with the 511 converter.

### 9.2 Shipping and storage

To prevent the product from damage during shipping, keep the original package of manufacturer. The products should be stored in storehouse that meets following conditions:

- a) Keep off raining and moisture;
- b) Keep off heavy vibration, and strike;
- c) Ambient temperature  $-20\sim+60^{\circ}\text{C}$ ;
- d) Humidity less than 80%.

## Appendix One: Selection of exciting frequency (re.)

511 afford three exciting frequency types: 1/10 frequency (type 1), 1/16 frequency (type 2), 1/25 frequency (type 3) and 1/32 frequency (type 4). The small-bore one should use 1/10 frequency, and large-bore one should use 1/16 or 1/25 frequency. When using, please select type 1 first, if the zero of velocity is too high, select the type 2 or type 3.

In the user's sensor that 511 gives, often the sensor is not fit for the 511 converters, at this time can do like this:

### (1) Small exciting loop resist

If the exciting loop resist is smaller than the sensor's request, can series resist to get the total value. The series resist's power should be more than one time of fact, for example, series  $10\Omega$  on 250mA current, the power will be 3W.

### (2) Large exciting loop resist (change exciting current)

If the exciting loop resist is larger than the sensor's request, can change the exciting current, for example, if exciting loop resist is  $70\Omega$ , for 250mA this is larger, so can change the current to 187mA.

### (3) Large exciting loop resist (change loop connect)

If the exciting loop resist is larger than the sensor's request, can change the connect of

loop, for example, if exciting loop resist is  $200\Omega$ , every exciting loop resist is  $100\Omega$ , parallel connection the upper and lower loop is OK.

According the analysis, change the connect of exciting loop, measure from either head of exciting loop,

$$\text{Total resist} = (R_1 + R_{L1}) \text{ parallel connection } (R_2 + R_{L2}) \leq 120\Omega;$$

(As the Fig.  $R_1, R_2$ ----addition resists;  $R_{L1}, R_{L2}$ ----exciting resists)

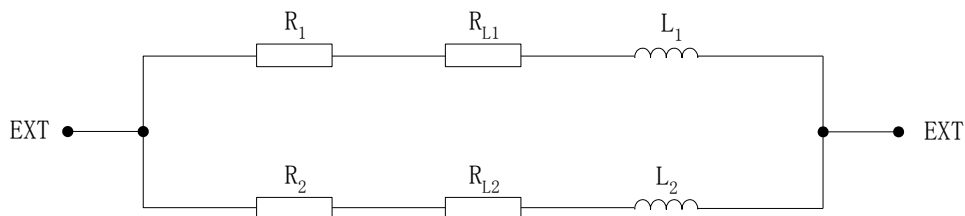

$$\text{Total resist} = (R_1 + R_{L1}) \text{ parallel connection } (R_2 + R_{L2}) \leq 120\Omega;$$

( as the Fig.  $R_1, R_2$ ----addition resists;  $R_{L1}, R_{L2}$ ----exciting resists)

(4) Sensor exciting current steady time so long (inductance is too large)

For this question, firstly changing exciting type, select 1/16 or 1/25 frequency.

If cannot content, change connect of exciting loop.

$$\text{Exciting current transition time } \tau = L / R$$

L ---- Exciting loop inductance; R ---- exciting loop resist.

So decrease L and increase R both can decrease  $\tau$ .

According the analysis, change the connect of exciting loop, measure from either head of exciting loop,

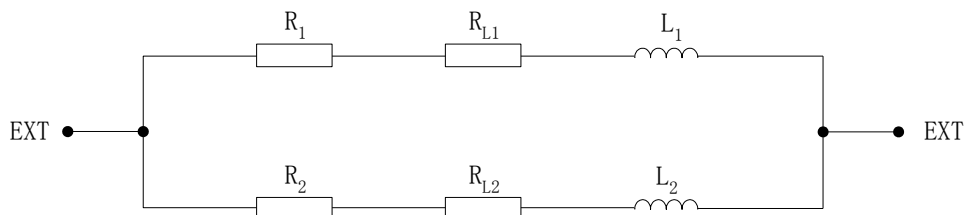



Total resist =  $(R_1 + R_{L1})$  parallel connection  $(R_2 + R_{L2}) \leq 120\Omega$ ;

(As the Fig.  $R_1, R_2$ ----addition resists;  $R_{L1}, R_{L2}$ ----exciting resists)

## Appendix Two: Analog Loop Communication function explanation

### 1. Analog Loop Communication Bus network .

Analog Loop Communication Bus transfers data-signal through signal line which value is from 4 to 20mA. For this reason, it can save local data communication line and implement data communication. Its adaptive for local using. The local network fig composed by Analog Loop Communication Bus is as follows:

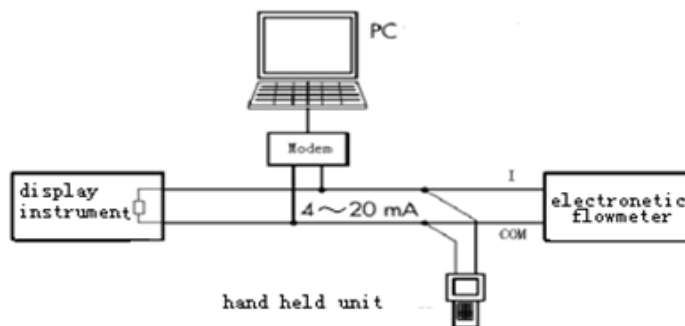

### 2. Instruction for setting of the converter

1. If you use the handset of our company, you need to set the meter address to 1 and set the baud rate to 4800;

2. If you use other handset such as 375 or 275, you need to set the meter address to 2 and

set the baud rate to 4800; (This function is according to the real object please)

3 If the communication mode, the address or the baud rate of the meter is not set correctly, the handset can't set the parameters.

3. Matters need attention of Analog Loop Communication using function meter

- 1) Load which is parallel connection between electrical flowmeter and Hand held unit and Analog Loop Communication MODEM is on polarity.
- 2) Resistance of circuit should be greater than  $200\Omega$ , less than  $500\Omega$ .
- 3) Hand held unit and Analog Loop Communication MODEM shouldn't be connection in series in current circuit. Set the baud rate to 4800;

## Appendix Four: 511 series with nonlinear amendment function Additional Instruction

Nonlinear amendment function, in principle is used for line regulation of low flow which under  $0.3\text{m/s}$ . The function is designed to four amendments, and divided into four flow velocity points and four correction factors.

Nonlinear amendment coefficient works on the basis of the original transducer calibration coefficient, so please close nonlinear amendment function before calibrating the transducer coefficient, and open the function to realize nonlinear amendment after calibrating. Set correction points and correction factors according to the nonlinear segment of transducer, if be the appropriate settings, do not have to recalibration.

As a rule, the flow velocity which calculated from transducer coefficient is called original flow velocity, and the other which gained from non-linear amendment is called correction flow velocity. The relationship between them is shown as following:

a. Correction point 1 > Original flow velocity  $\geq$  Correction point 2:

Correction flow velocity = Correction coefficient 1  $\times$  Original flow velocity

b. Correction point 2 > Original flow velocity  $\geq$  Correction point 3:

Correction flow velocity = Correction coefficient 2  $\times$  Original flow velocity

c. Correction point 3 > Original flow velocity  $\geq$  Correction point 4:

Correction flow velocity = Correction coefficient 3  $\times$  Original flow velocity

d. Correction point 4 > Original flow velocity  $\geq$  0:

Correction flow velocity = Correction coefficient 4  $\times$  Original flow velocity

Notice: Correction points must satisfy the following relationship:

Correction point 1 > Correction point 2 > Correction point 3 > Correction point 4

The intermediate value of correction coefficient is 1.0000, when bigger than it is considered as positive coefficient (increase), and smaller is considered as negative coefficient (decrease).

## AppendixFive:The function of protecting the Characteristic Flow Factor

-B converter has a function of protecting the Characteristic Flow Factor. The key content is that the factor could not be modified easily. B converter increases a new

function to record the modified procedure and modified times of flow zero, sensor factor, and meter factor, any change of these three factors could be recorded. The sensor factor and modifying times could be recorded in Test Report, and when next time testing the factor in Test Report and factor in the convertor are compared to check whether the Characteristic Flow Factor has been changed. The detail about the Characteristic Flow Factor protection function can be found in the appendix.

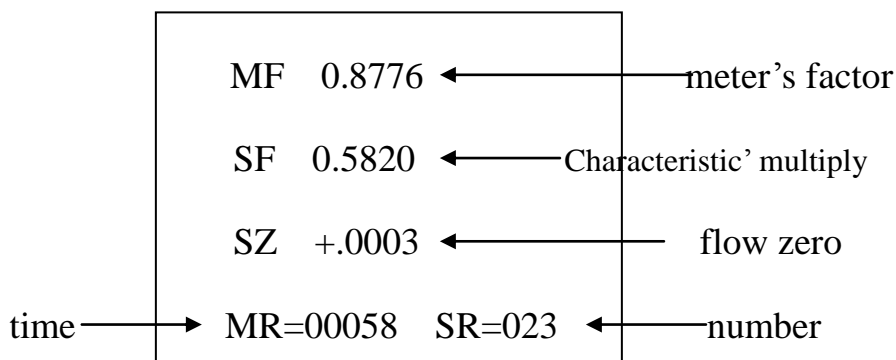

### Attention !

The last record is displayed when this item is first entered, if you want to browse the history records press “down key”, and could search for the last record to the thirty-two record ahead. Finally the times of record modified (MR) should be written down on the paper before next time test.

## Appendix six Lightning protection notes

When installing, users must connect the converter's earthing terminal with the shell, and then earthing them reliably, because the electrical current can be put into the earth

through the shell by the gas discharger of lightning protection. If the shell has not been earthing reliably, once lightning, it may cause a personal accident when there is somebody operating the converter. The specific details, you can see the connection diagram.

1、 511

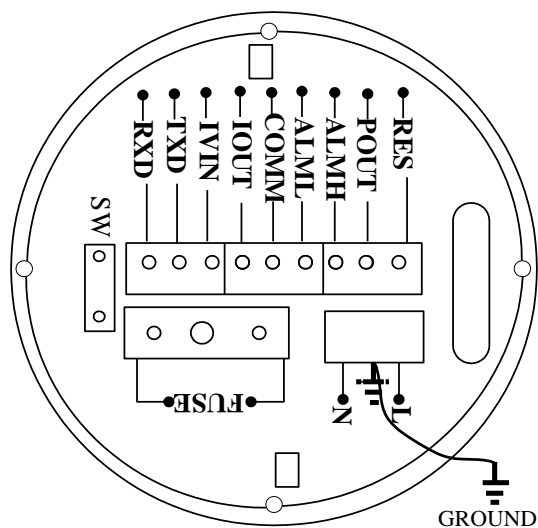

2、 511B

